

1. Scope

The document detail the electrical, mechanical and environmental specifications of a SMPS, the power supply provide **96W** continuous output power.

The power supply shall meet the RoHS requirement.

Description

- SMPS Adaptor(Wall mount)
 SMPS Adaptor(Desk-top)
- Open Frame
 SMPS Unit (With Case)
- Others

2. Electrical Specification

2.1 INPUT

Input voltage range	90Vac-264Vac / 100Vac-240Vac
Rated voltage range	100Vac-240Vac
Input frequency range	47Hz-63Hz
Rated input frequency	50Hz/60Hz
Input AC current	≤0.6Arms at 100 to 240Vac input
Inrushcurrent c	lower than 50/80 A under cold start and 1st half cycle of 115/230 Vrms
(oldstart ut Fuse	The input fuse shall not blow up.
No load power dissipation	≤0.21W max. @230Vac/115Vac input & No Load.
AC Leakage Current	0.05mA Max @230Vac input.

2.2 OUT PUT

TEST MEASURES

C1: 0.1uF CERAMICS CAPACITOR C2 : 10uF 50V ALUMINUM CAPACITOR

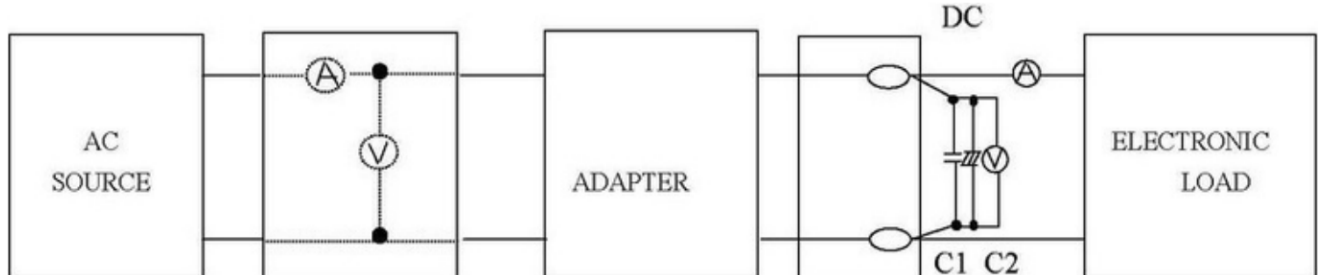

MODEL NO.: AV-PSN-24V-100W DESIGNED NO. _____

2.2.1 Rated Output

output voltage (Vdc)	output voltage Limit (Vdc)	Output Ripple & Noise (mV)	Output Current (mA)
24V	22.8-25.2	≤120	4000mA

Notes

(Ripple Voltage is measured with oscilloscope with bandwidth 20MHz . A 10uF ceramic-cap shall be connected to the connector in parallel.) Block diagram as following:

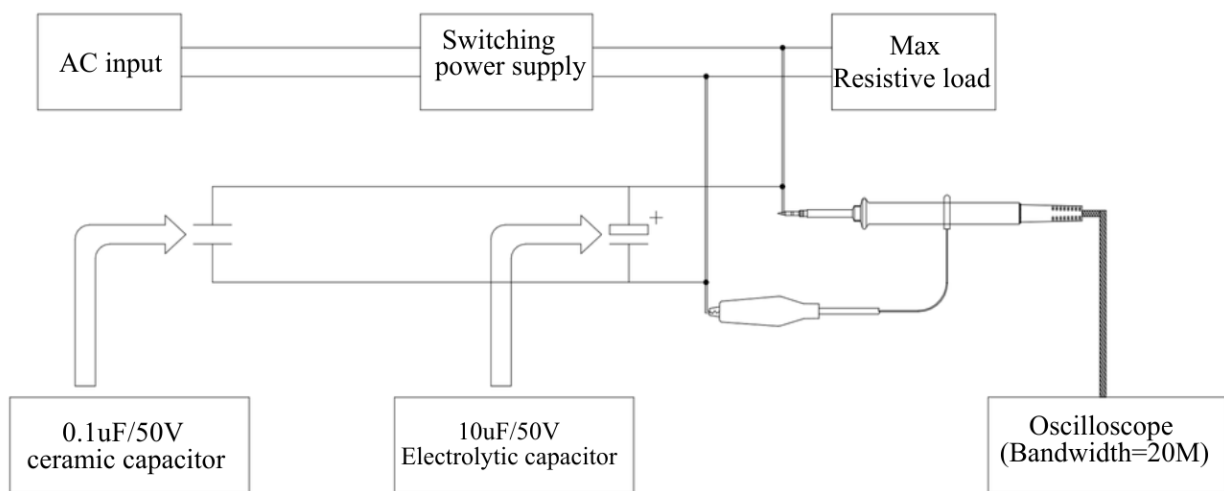

2.2.2 DC Output Overshoot At Turn On & Turn off

output voltage (V)	Proportion of the output voltage overshoot	
	Turnon	Turnoff
24V	5%	5%

Notes: All of dc output current for Min. to Max)

2.2.3 Combined Load/Line Regulation

voltage	Min. load	Rated.Load	Line Regulation	Load Regulation
24Vdc	0A	4A	±2%	±5%

%

2.2.4 Turn on delay time

3s max@ 100Vac to 240Vac input and output Max.Load

2.2.5 Rise time

2.2.6 Hold up time

30ms max@100Vac to 240Vac input and output Max.Load

2.2.6 Holduptime

10mS/20mS Min. at 115Vac/230Vac input and output Max. Load.

2.2.7 Efficiency

In 230 Vac / 115 Hz and 230Vac / 60 Hz input , The output at 2 % 0 % , 75% and full load cases ,The average efficiency of $\geq 87\%$ (testing after 30 minutes),And no-load input power $0.\leq 21W$.

ENERGY STAR Program Requirement

Nameplate Output Power(Po)	Average Efficiency in Active Mode expressed as a decimal
$P_o \leq 1$	$\geq 0.5 \times P_{out} + 0.16 (V_{out} > 6V); \geq 0.517 \times P_{out} + 0.087 (V_{out} > 6V)$
$1 < P_o \leq 49$	$\geq 0.071 \times \ln(P_{out}) - 0.0014 \times P_{out} + 0.67$; $\geq 0.0834 \times \ln(P_{out}) - 0.0014 \times P_{out} + 0.609 (V_{out} \leq 6V)$
$P_o \geq 49$	$\geq 0.88 (V_{out} > 6V); \geq 0.87 (V_{out} \leq 6V)$

Average Efficiency in active Mode

Energy Consumption criteria for No load

Nameplate Output Power(Po)	Maximum Power in No-Load
0 to <50 watts	≤ 0.10 watts
≥ 50 to ≤ 250 watts	≤ 0.21 watts

3. Protection function model

3.1 Short circuit protection:

The power supply shall not be damaged by short between DC output and DC ground. The power supply shall automatically restart when short to ground are removed.

3.2 Over current Protection

The power supply shall be in protection status when the over currents applied to the output rail, and shall be self-recovery when the fault condition is removed.

AC Input voltage	Over Current Protection	Short Circuit Protection
100-240Vac	5.2A-7.1A	Hiccup

3.3 Over Voltage Protection

When the output over-voltage, the power supply into the hiccup protection status, and shall be self-recovery when the fault condition is removed.

4. Reliability Requirements

4.1 (Burn-in)

Products need to be burned-in 2-4 hours and the 80% of the load.

4.2 MTBF Qualification

*Standard: MIL-HDBK-217F

The MTBF shall be at least 30,000 hours at 25 °C, Full load and nominal input condition

Output Voltage	Min Voltage	Max Voltage	Current	MTBF	Load Condition
+24VDC	+22.8Vdc (-5%)	+25.2Vdc (+5%)	4.0A	30000Hr	100%

4.3 Hi-Pot test

1) Hi-Pot tests (Dielectric withstand voltage)-CLASS II

: leakage (cutoff) current 10mA

: Safety Test:

Primary To Secondary : 3000Vac, 1 minute for type test

Production Line:

Primary To Secondary : 3000Vac, keeping 2 seconds for production

* Test methods: Input test voltage beginning from zero to 3600Vac in 0.5s. We move plug after discharge display 0V.

* Test point : Primary Live and Natural Short ↔ Secondary

2) Hi-Pot tests (Dielectric withstand voltage)-CLASS I

MODEL NO.:	AV-PSN-24V-100W	DESIGNED NO.	
------------	-----------------	--------------	--

: leakage(cutoff) current 10mA

: Safety Test:

Primary To GND : 1500Vac ,1 minute for type test

Primary To Secondary : 1500Vac ,1 minute for type test

Production Line:

Primary To GND : 1800Vac ,keeping 2 seconds for production

Primary To Secondary : 1800Vac ,keeping 2 seconds for production

* Test methods:Input test voltage beginning from zero to 1800Vac in 1s.We move plug after discharge display 0V.

* Test point : Primary Live and Natural Short ↔ Ground

4.4 Lighting Surge

The Power Supply must satisfy Table's Lighting Surge Spec.

1) Test Condition

Products	Test Voltage	Test Point & Test Mode	Number of Test times
Adapter	±1KV	Line to Line : C-Mode	± Each Voltage 3-ti mes
N/A	N/A Line to Gnd : CR-Mode	Line to Gnd : CR-Mode	

Note:

a. Environment Requirements: temperature :15~ 35°C; humidity :10%~ 75%RH

b.Surge voltage is applied to the phase: 0° 90° 180° 270°

c.Surge voltage is applied: for each polarity voltage of each repeated 5 times, a phase done 10 times,each applied voltage interval of 60 seconds

4.4 Insulation Resistance

nsulation resistance shall be more than 10MΩ at 500Vdc between Primary Live, Primary Neutral and secondary

MODEL NO.:	AV-PSN-24V-100W	DESIGNED NO.	
------------	-----------------	--------------	--

5. Environmental Requirement

5.1 Operating Temperature

0°C to 40 °C, 0~80%load, Normal operation.

5.2 Storage Temperature

-40°C to 85 °C with case

5.3 Relative Humidity

5% (0°C) ~95 % (40 °C) RH , 72 hours 0~ , 80 %load Norm, a loperating.

5.4 Vibration

5.4.1 Testing Standard: International Electrotechnical Commission (IEC)

Operating : IEC 721-3-3 3M3

5~9Hz, A=3.5mm

9~200Hz, Acceleration 5m/S

5.4.2 Transportation

IEC 721-3-3 2M25~9Hz , A=3.5mm

9~200Hz, Acceleration= 5m/S

200~500Hz, Acceleration= 15m/S

5.4.3 Axes: 10 cycles per axis:

No permanent damage may occur during testing.

The product can restore to its original situation after power off / on.

5.5 Dropping Packed

1 corner, 3 edges, and 6 surfaces.

Height 76cm

5.6 Operation Altitude

→0-5000m

MODEL NO.:	AV-PSN-24V-100W	DESIGNED NO.	
------------	-----------------	--------------	--

6. Safety and EMI Requirement :

6.1 Safety: accord with

Certificate	Country	Standards	
<input checked="" type="checkbox"/> UL/CUL	USA	UL1310	
<input checked="" type="checkbox"/> UL/CUL	USA	UL62368 60950	
<input type="checkbox"/> T UV/GS	Europe	EN60065	
<input checked="" type="checkbox"/> T UV/GS	Europe	EN62368 60950	
<input checked="" type="checkbox"/> FCC	USA	Class B	
<input type="checkbox"/> CE	Europe	EN60065	
<input checked="" type="checkbox"/> CE	Europe	EN62368 60950	
<input type="checkbox"/> MEPS	Australia	As/NZS 4665	
<input type="checkbox"/> SAA	Australia	As/NZS 60065	
<input checked="" type="checkbox"/> SAA	Australia	As/NZS62368 60950	
<input type="checkbox"/> CCC	China	GB8898	
<input checked="" type="checkbox"/> CCC	China	GB4943	
<input checked="" type="checkbox"/> PSE	Japan	J62368 60950(H22)	
<input type="checkbox"/> CB	Europe	IEC60065	
<input checked="" type="checkbox"/> CB	Europe	IEC62368 60950	
<input checked="" type="checkbox"/> C-T ICK	Australia	As/NZS CISPR13: 2004	
<input checked="" type="checkbox"/> EK/K C	Korea	K60950	

6.2 IEMI STANDARD

EN55032	EN55015
GB17625	GISPR 22
GB9254	FCC Part15

6.3 EMS Standards/

EN 61000-3-3	Voltage fluctuations & flicker;
EN 61000-4-2	Electrostatic Discharge(ESD): 8kV air discharge, 4kV contact discharge;
EN 61000-4-3	Radio-Frequency Electromagnetic Field Susceptibility Test-RS;
EN 61000-4-4	Electrical Fast Transient/Burst-FET;
EN 61000-4-5	Surge Immunity Test: AC Power Line: line to line 1kV, line to earth 2kV;
EN 61000-4-6	Conducted Radio Frequency Disturbances Test-CS;
EN 61000-4-8	Power Frequency Magnetic Field Test;
EN 1000-4-11	Voltage Dips;

MODEL NO.: AV-PSN-24V-100W DESIGNED NO. _____

6.3 Dielectric Strength Testing

Hi-pot test shall be met the table 5 requirements, an item listing this test as a 100% production test must be performed and be maintained at that level for a minimum of 5 seconds without failure.

7. Test Equipment List

Project	Device name item	manufacture	model
1	AC power source	Chroma	6120
2	Oscilloscope	Tektronix	TDS1002B
3	Electronic load	TET	T3515
4	Multimeter	FLUKE	87 III
5	Dynamometer	Chroma	2100
6	Thermograph	LUTRON	TW-902C
7	Drop test bed	self made	

8. MECHANICAL REQUIREMENT

8.1 Enclosure

The power supply size: 153mm*60mm*38mm

8.2 Input Connector

Two pin input connector/ C8

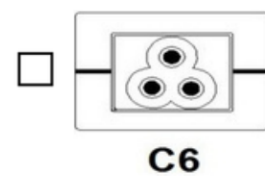
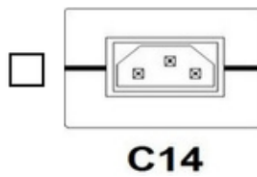
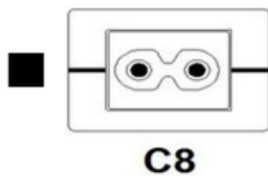

MODEL NO.: AV-PSN-24V-100W DESIGNED NO. _____

9. MECHANICAL SPECIFICATIONS

9.1 Dimension:

153mm*60mm*38mm (L * W * H)

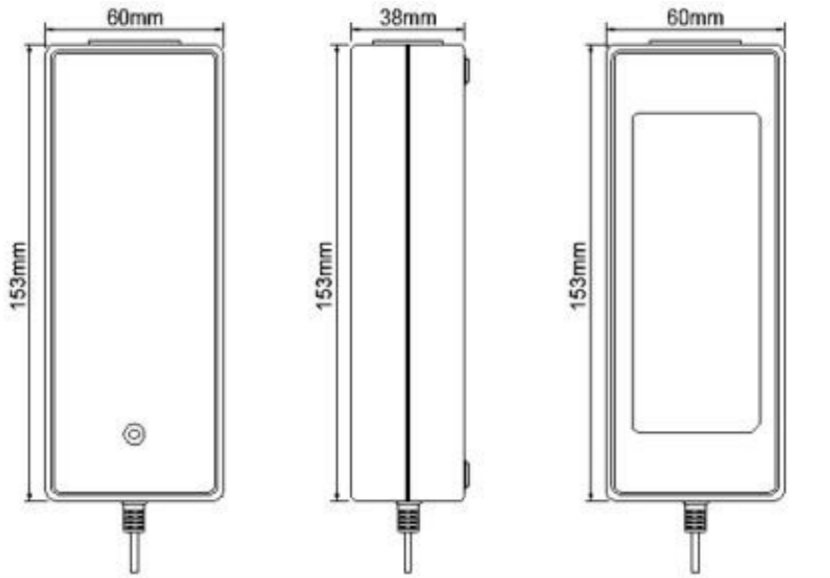

9.2 DC output cord Drawing

See picture 1.2M DC cable 2464# 18AWG DC head: 5.5*2.1mm

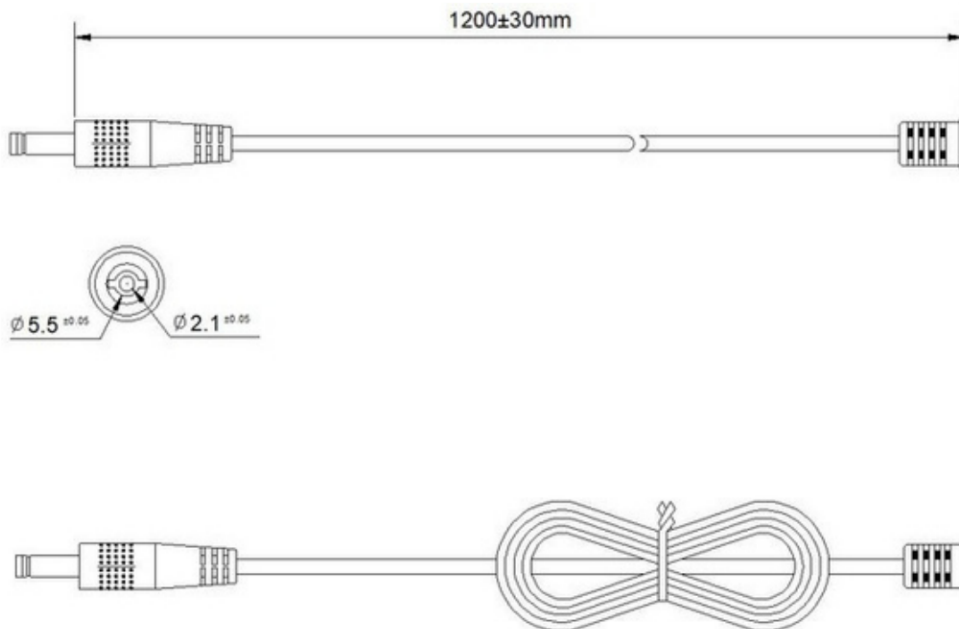

MODEL NO.:	AV-PSN-24V-100W	DESIGNED NO.	
------------	-----------------	--------------	--